

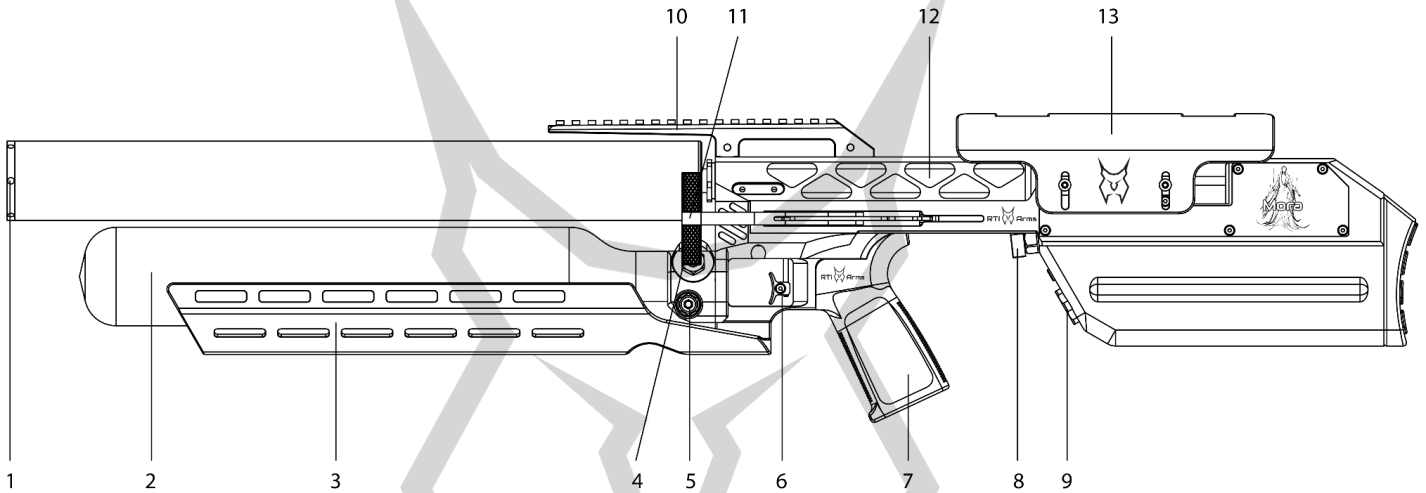

RTI Mora Shooter's Manual

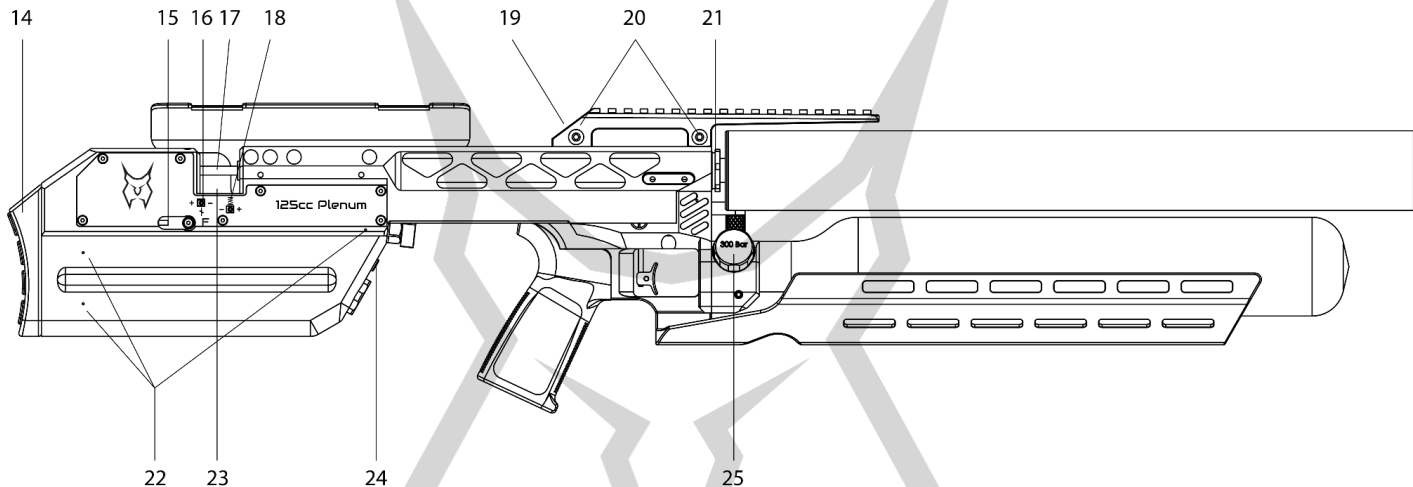

1. Shroud end cap with suppressor adapter (female M15x1)
2. Air pressure bottle
3. M-Lok bottle shield
4. Second stage regulator adjustment
5. Fill probe
6. Trigger
7. AR15 Grip
8. Valve dwell time adjustment knob
9. Regulated pressure gauge
10. Picatinny rail
11. Cocking handle
12. Barrel
13. Cheek piece



- 14. Butt pad
- 15. 180 degree safety
- 16. Trigger sear engagement setting
- 17. Projectile probe
- 18. Trigger weight of 2nd stage
- 19. Elevation adjustability screw

- 20. Picatinny side screws
- 21. Barrel nut
- 22. Witness holes
- 23. Magazine gap
- 24. Degassing screw
- 25. Tank pressure gauge

Congratulation!	6
Warnings	7
Manual Safety	9
Handling	10
Cocking the rifle.....	10
Decocking the rifle.....	11
Accessories.....	11
Elevation Adjustable Picatinny Rail for Optics Mount:.....	12
Bottom Rear M-Lok Compatibility.....	13
Front M-Lok Compatibility on Left and Right Sides:.....	14
Front Bottom M-Lok Compatibility:.....	14
Filling your RTI	16
Degassing/Emptying.....	17
Loading the Magazine	18
How to use the Mora	19
Inserting the Magazine.....	19
Stopping Shooting.....	19
Removing the Magazine.....	20
Adjustments on Your Mora Airgun	21
Pressure Regulator.....	21
Second Stage Regulator.....	21
First Stage Regulator.....	23
Hammer Spring Tension.....	24
Valve Dwell Time.....	25
Headspace Adjustment.....	27
Trigger Adjustment.....	28
Buttpad Adjustment.....	31
Barrel change	33
Maintenance	35
Witness holes.....	35
Miscellaneous Information	37



RTI Arms

Congratulation!

You've just acquired an RTI Arms airgun, a marvel of precision and power. Now, go forth and conquer... targets, that is. Remember, with great air comes great responsibility. Enjoy your new piece of awesomeness, and may your shots always be true!

Share Your Experience:

- **Show Off:** Make sure to share videos and photos of your shooting adventures on our social platforms. Let the world see your marksmanship! Don't forget to tag us!
- **Follow Us:** Stay updated with the latest from RTI Arms by following us on all our social media channels:
 - **X:** @rtiarms
 - **Instagram:** @rtiarms.eu
 - **YouTube:** @rtiarms
 - **Facebook:** @rtiarms

Join the community, share your tips, tricks, and triumphs, and be part of the RTI Arms family. Happy shooting!



Warnings

- **Not a Toy:** This is not a toy. It's a precision instrument for serious people.
- **Eye Protection:** Always wear eye protection. Because losing an eye over a pellet gun would be a very poor life choice.
- **Never Point at People:** Unless you're aiming to start a very one-sided argument, keep the gun pointed in a safe direction.
- **Treat It Like a Real Firearm:** Because, let's be honest, it's close enough. Always assume it's loaded, even if you're pretty sure you left it empty.
- **Keep Fingers Off the Trigger:** Until you're ready to shoot. This isn't a video game; there's no respawn.
- **Check Your Backstop:** Make sure what's behind your target is something you're okay with shooting. Like, maybe a pile of old bills or your ex's photo.
- **Don't Modify the Gun:** Unless you're a certified gunsmith or just really want to void your warranty in style. But if you do decide to get creative, don't forget to send us a photo. We love seeing what our customers come up with, even if it's technically against our advice. Just remember, if it breaks, you're on your own.
- **Don't Disassemble:** Unless you're a certified gunsmith or enjoy the thrill of putting things back together with parts left over.
- **Only Fill with Regular Air:** No helium, no CO2, and definitely no laughing gas. This isn't a party balloon; it's a serious airgun.
- **Carbon Fiber Tank Inspection:** If you're using a carbon fiber tank, make sure to inspect it according to local laws.
- **Store Safely:** When not in use, lock it up. Because if your cat learns to shoot, you've got bigger problems than just a messy litter box.
- **Be Aware of Your Surroundings:** Because if you're not, your day might end with a lot more excitement than you planned. If you

choose to disregard this, just make sure your insurance is up to date.

- Keep Dry: Water and airguns don't mix. Unless you're shooting at water, but then, you're just asking for a wet gun.
- Lubrication: Use silicon oil for the O-rings, because they like to stay flexible and happy. For all the steel parts, give them a good lube to keep rust at bay. Remember, a well-oiled gun is a happy gun, but don't turn it into a slip 'n slide.
- Read the Manual: Because ignorance might not be bliss when it comes to your safety.

Remember, with great power comes great responsibility. Or at least, the responsibility not to shoot your foot off. Enjoy your airgun, but stay safe!



RTI Arms

Manual Safety

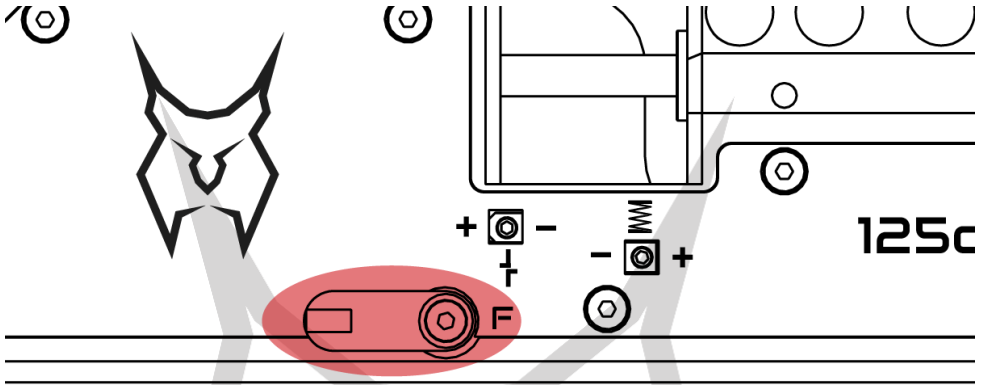

Your Mora airgun comes with a manual safety located on the right rear side of the gun. Here's how it works:

- **Safety Mechanism:** This is a 180-degree safety. When you turn it fully to the S position, the hammer is pushed back, and the trigger sear disengages. This means even if your gun takes a tumble, it won't go off.
- **Engaging the Trigger:** Before you can pull the trigger, make sure the gun is fully cocked.
- **Disengaging Safety:** To disengage the safety, simply rotate the safety 180 degrees to the F position.

Important Note: If your trigger is set too light, there's a chance the gun might fire when you disengage the safety. Always test this and adhere to all firearm safety protocols. Remember, safety first, or you might end up with an airgun that's more of a party popper than a precision shooter!

Handling

Cocking the rifle

To get your airgun ready to fire:

- **Pull the Handle Back:** Give it a good yank all the way back. This action cocks the hammer by locking it against the trigger sear.
- **Rotate the Magazine:** If you've got a magazine in, this movement will also give it a spin.
- **Push Forward:** Shove the handle all the way forward.

Voilà! Your rifle is now ready to send projectiles on their merry way. Remember, handle with care; this isn't a toy, it's a precision instrument of plinking pleasure!

Warning

Ensure Proper Closure: Always make sure that you move the cocking handle **all the way forward in battery** (locked position). If the handle is not fully seated, the sudden release of air can cause a **loud pop** to escape from the rear of the gun, which is dangerously close to your ear.

If Handle Sticks:

- **Cock Again:** If the handle does not close fully, recock the rifle.
- **Safety On:** Engage the safety to prevent accidental discharge.
- **Clear the Barrel:** Use a long rod (one that's slightly smaller in diameter than your barrel's caliber) to gently push out any projectiles that might be stuck. This could happen if the pellets or slugs are too large for your barrel.

Remember, safety first! A loud pop next to your ear can not only startle you but potentially harm your hearing. Always ensure the rifle is in proper working order before firing.

Decocking the rifle

To safely decock your rifle:

- **Pull Back and Hold:** Grab the cocking handle and pull it all the way back. Keep a firm grip on it.
- **Press the Trigger:** With your other hand, press the trigger.
- **Ease Forward:** While holding the trigger down, gently move the cocking handle forward until it's fully seated.

Decocked! Your gun is now in a safe, non-firing state.

Pro Tip: If you've got a magazine in, **remove it first** to avoid accidentally double-loading. Double the ammo doesn't mean double the fun; it means double the trouble!

Accessories

Your rifle is ready for customization with Main Picatinny rail and M-Lok Mounting Points which are scattered across the gun, giving you plenty of options to attach all sorts of goodies.

So, go ahead, deck it out, and make your airgun as unique as your personality!

Elevation Adjustable Picatinny Rail for Optics Mount:

Purpose: This rail is designed for mounting your optics, and it comes with an elevation adjustment feature for coarse tuning your shot.

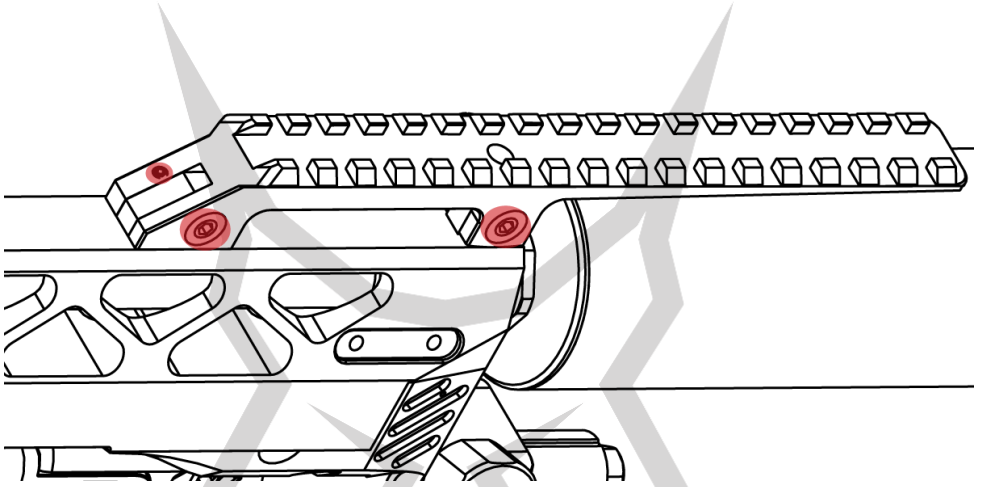

Adjustment:

- **Unscrew:** First, loosen the two side screws using 3mm hex tool.
- **Elevate:** Turn the small grub screw using 2mm hex tool clockwise to raise the rail. Each full turn equals 27,50 MOA or 8 MIL.
- **Secure:** Once you've got your desired elevation, tighten those side screws back to 6 - 7 Nm to lock it in place. Make sure you use great or oil lubricant below the screw head.

This setup lets you tweak your scope's elevation for longer shots without needing to fiddle with the scope itself. Remember, this is for rough adjustments; fine-tuning is still up to your scope's dials!

Bottom Rear M-Lok Compatibility

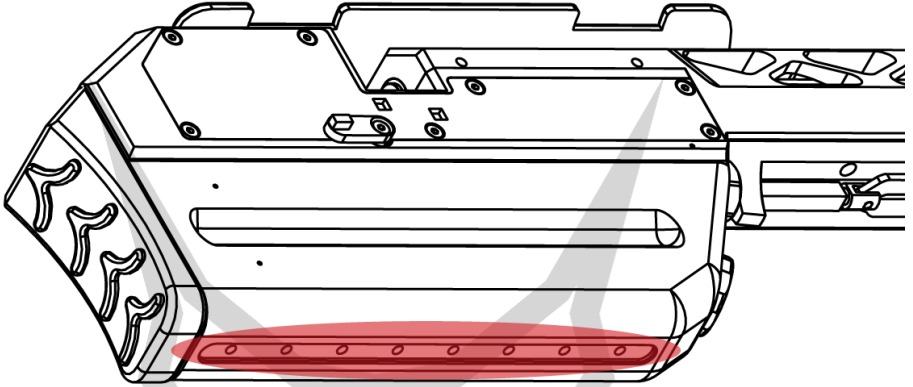

There are M-Lok holes on the bottom of the rear block. This means you can attach M-Lok compatible accessories right there, like a monopod or a sling mount.

Use the M4 screws which are usually supplied with the M-Lok accessory.

RTI Arms

Front M-Lok Compatibility on Left and Right Sides:

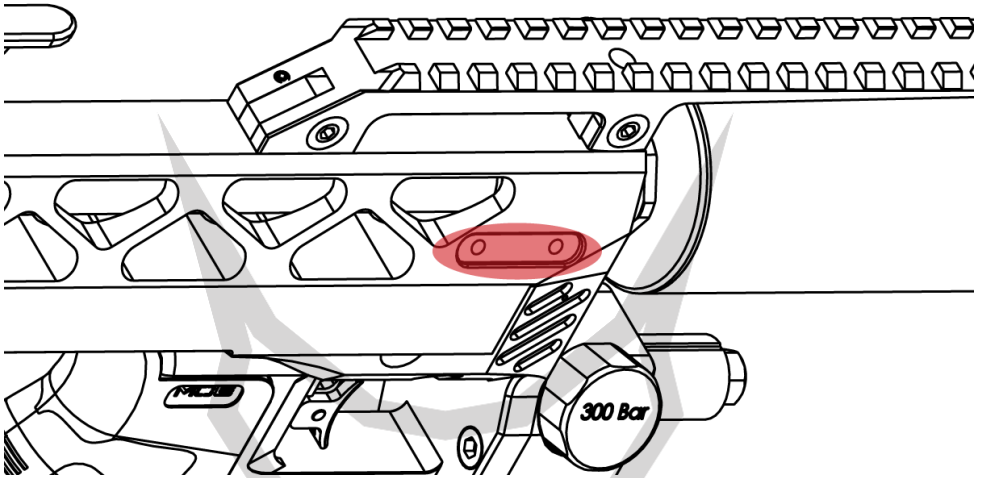

M-Lok slots on both sides of the front allow for even more accessory options.

Front Bottom M-Lok Compatibility:

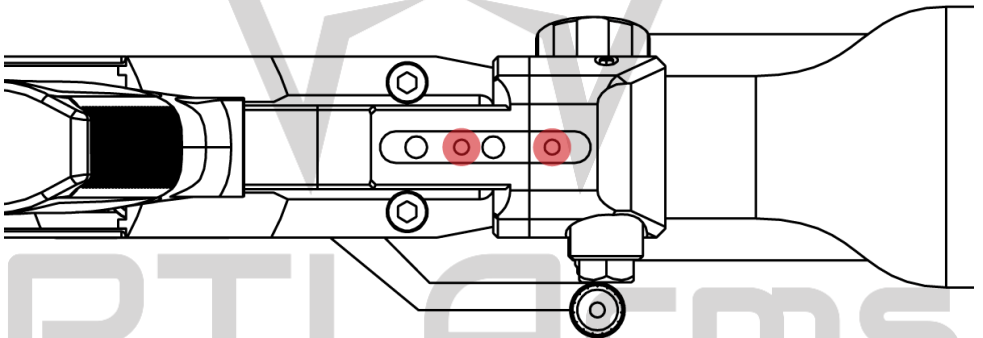

This spot is perfect for mounting a Picatinny rail or an M-Lok bipod. Whether you're looking for stability or extra mounting options, this is your go-to area.



RTI Arms

Filling your RTI

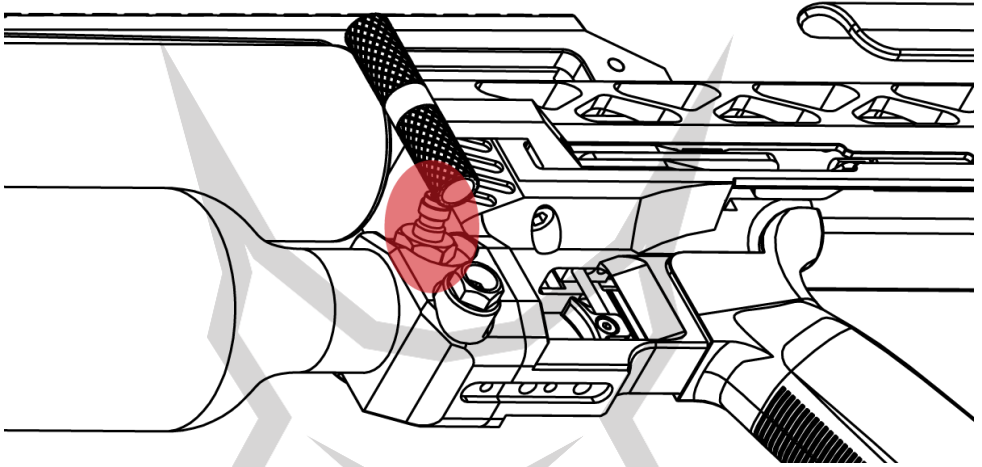

Filling Nipple: Your rifle comes with a standard filling nipple, conveniently placed near the air bottle.

How to Fill:

- **Connect:** Use a standard quick-connect Foster fitting. Push it onto the nipple until you hear or feel it snap into place.
- **Follow Instructions:** Adhere to the guidelines of your filling source to avoid overcharging.
- **Pressure:** The tank can handle up to 300 bar. Use a precise pressure gauge to ensure accuracy.
- **Bleed and Disconnect:** After filling, bleed any remaining air from the hose and then disconnect the quick-connect.

Recharge: Refill when the front gauge reads the same pressure as the rear gauge.

Warning: Only use dry air for filling. Using any other gas can lead to catastrophic failure, resulting in serious injury or worse. Stay safe, not sorry!

Degassing/Emptying

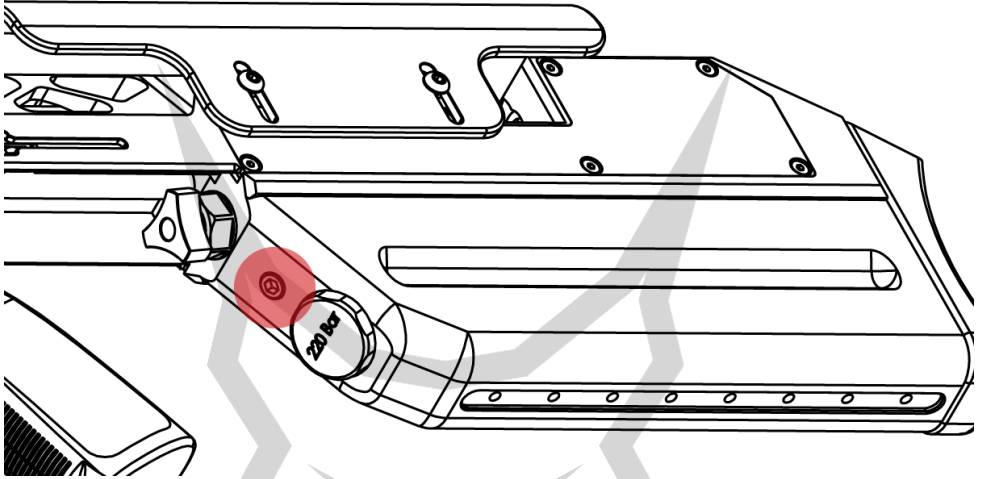

Grub Screw Location: Find the grub screw above the rear pressure gauge.

Degassing Process:

- **Unscrew:** Loosen the grub screw by one full turn.
- **Listen:** You should hear air escaping. Wait until the air stops leaking.
- **Tighten:** Once the air has fully bled out, tighten the screw back to 3.5 Nm.

This procedure ensures your rifle is safely depressurized, ready for maintenance. Remember, safety first, even when you're just letting out some air!

RTI Arms

Loading the Magazine

- **Rotate the Drum:** First, turn the inner drum all the way around to tension the spring.
- **Insert First Projectile:** Place the first projectile to the first hole to lock the drum in place.
- **Fill the Rest:** Now, you can freely fill the remaining holes with projectiles.
- **Tap to Set:** Hold the magazine in one hand and give it a gentle tap against your other hand. This ensures each projectile passes at least one O-ring, preventing them from falling out the back.

This method ensures your magazine is loaded correctly and securely, ready for action. Remember, a well-loaded magazine is the key to a smooth shooting experience!

A large, light gray watermark logo of an owl is centered on the page. The owl's head is at the top, with its wings spread out to the sides. The logo is composed of thick, geometric lines.

RTI Arms

How to use the Mora

Inserting the Magazine

1. **Cock the Rifle:** Pull the cocking handle back until it locks.
2. **Engage Safety:** Flip the safety to the "S" position.
3. **Insert Magazine:** Slide the full magazine in until you hear or feel a click, indicating it's locked.
4. **Close the Lever:** Push the cocking lever forward. The gun is now chambered.

Safety Note: Always adhere to gun safety rules. Each time you cock, a round is chambered. If chambered, it must be shot; it can't be ejected.

Double Feed: If you cock again without firing, you'll double feed. If this occurs:

- Stop firing.
- Remove the magazine.
- Decock the rifle.
- Remove the barrel.
- Use a brass rod close to the caliber to gently tap out the projectiles.

Stopping Shooting

- **Remove Magazine:** Take out the magazine.
- **Fire to Empty:** Shoot to a safe direction to confirm the gun is empty.

Removing the Magazine

- **Cock the Rifle:** Pull back the cocking handle.
- **Remove Magazine:** Pull it out.
- **Decock or Dry Fire:** Either decock the rifle or do a dry fire shot into a safe direction to ensure no projectile remains in the chamber.

Remember, handling firearms, even airguns, requires respect for safety protocols. Keep it safe, keep it fun!

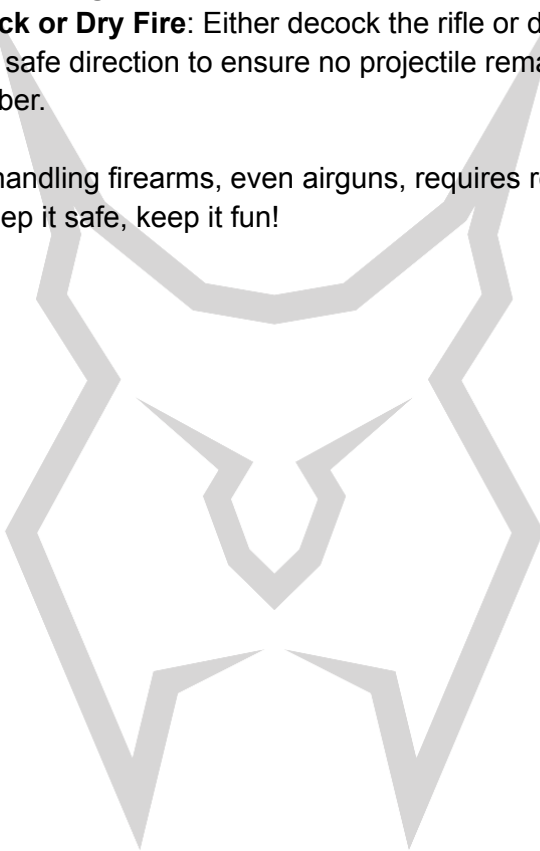

RTI Arms

Adjustments on Your Mora Airgun

- **Hammer Spring Tension:** Adjusting this can change the force with which the hammer strikes, making sure the valve opens consistently each shot.
- **Valve Dwell Time:** This controls how long the valve stays open, which impacts the amount of air released per shot, thus affecting shot consistency and power.
- **Pressure Regulator:** Fine-tune the air pressure to optimize performance for different projectile weights.
- **Headspace Adjustment:** Adjusting this can help in achieving the best accuracy when firing different types or length of projectiles.
- **Trigger Adjustment:** Adjusting the trigger to your liking for best accuracy.
- **Buttpad Adjustment:** Adjusting buttpad to best fit your needs.

These adjustments allow you to tailor your Mora airgun to your specific needs, whether it's for precision target shooting or plinking. Remember, each tweak can significantly alter how your rifle performs, so experiment carefully!

Pressure Regulator

Purpose: The first step in tuning your airgun is setting the correct pressure for your chosen projectile to achieve your desired velocity.

Second Stage Regulator

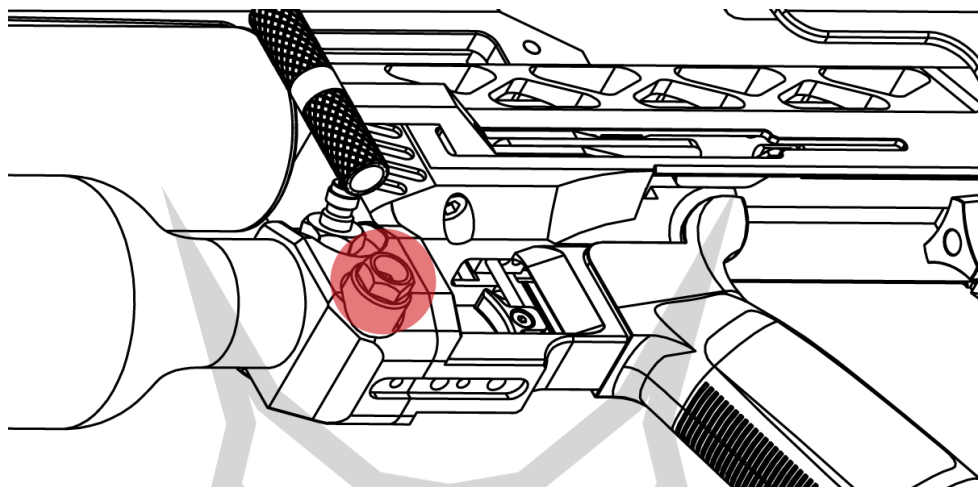

Adjustment Process:

- **Use Hex Tool:** Use a 6 mm hex tool for the adjustment screw.
- **Increasing Pressure:** Turn the screw clockwise to increase the pressure.
- **Decreasing Pressure:** Turn it counterclockwise to reduce pressure.

Important Notes:

- **Pressure Gauge:** The gauge showing regulated air pressure (at the rear) will only reflect changes when you increase the pressure.
- **Decreasing Pressure:** When you need to lower the pressure, begin by unscrewing the degassing screw (#24) just enough to start a slow leak. Slowly decrease the pressure by adjusting the regulator. This method helps in not stressing the regulator seal by allowing pressure to escape gradually.
- **Stabilization:** After setting your desired pressure, fire several more shots to ensure the regulator has stabilized and the pressure is consistent.

This method helps you find the sweet spot for your airgun's performance, balancing between velocity, air efficiency, and shot consistency.

Remember, small adjustments can make a big difference, so patience is key.

First Stage Regulator

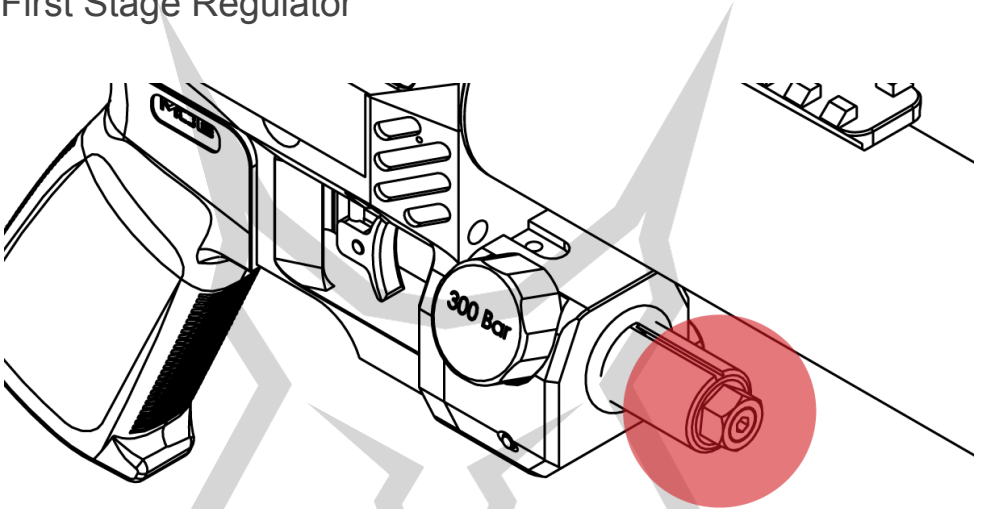

Accessing the First Stage Regulator:

- **Degas the Rifle:** Follow the degassing procedure to safely release pressure.
- **Remove the Bottle:** Take off the air bottle to access the first stage regulator.

Typical Setting: Generally, this regulator is set around 200 bar and doesn't need adjustments.

When to Adjust:

If you're aiming for very low pressures with the second stage regulator, you might want to adjust the first stage to be closer to the second stage's setting (about 20-50 bar higher).

Adjustment Process:

- **Use 4mm Hex:** Use a 4mm hex tool for the adjustment.
- **Decreasing Pressure:** Screw the adjustment screw in.
- **Increasing Pressure:** Loosen the adjustment screw.

Verification:

- **Refill the Bottle:** After adjusting, fill the bottle back to check your settings.
- **Check Pressure:** Set the second stage regulator to its maximum. The rear gauge will then show the pressure set by the first stage regulator. Ensure you only go up to 200 bar with the second regulator to avoid damaging it. Half turn is about 50 bar.

This process ensures your airgun's first stage regulator is tuned correctly, especially if you're looking to operate at lower pressures for specific shooting conditions. Remember, adjustments here can significantly affect the performance, so proceed with care.

Hammer Spring Tension

Understanding the Valve: The Mora's valve is an assisted binary valve, meaning it's either fully open or closed, which impacts how you adjust the hammer spring tension. You cannot adjust velocity with this setting!

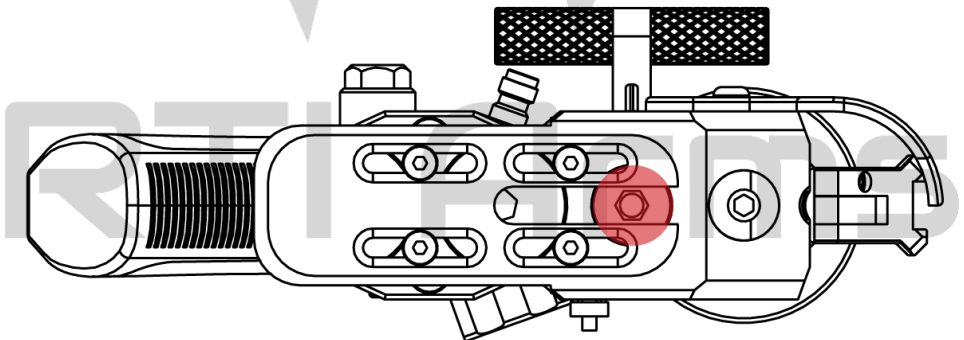

Adjustment Process:

- **Remove Buttpad:** First, take off the rubber buttpad to access the tensioner.
- **Use Hex Tool:** Employ a 6 mm hex tool to turn the tensioner screw.

Finding the Right Tension:

- **Start Low:** Unscrew the tensioner until it's flush, setting it to its lowest tension.
- **Incremental Increase:** Turn the screw in by half a turn and dry fire the gun.
 - **No Sound:** If you don't hear the valve opening (no sound when fired), increase by another half turn and dry fire again.
 - **Repeat:** Continue this process until you hear the shot being fired (valve opens).
- **Final Adjustment:** Once you hear the shot, add another half turn for optimal tension.

This method ensures the hammer has enough force to open the valve consistently, providing reliable shots but does not overpower the valve and introducing unnecessary vibration to the system. Remember, fine-tuning might require patience, but it's crucial for performance.

Valve Dwell Time

RTI Arms

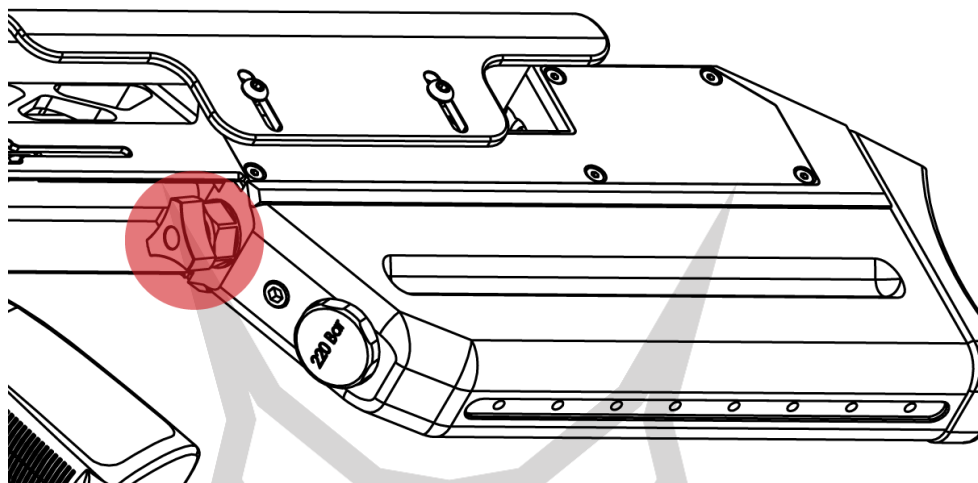

Understanding Valve Dwell Time: This setting controls how long the valve remains open, directly affecting the amount of air delivered to the barrel, which in turn impacts velocity and air consumption.

Adjustment Process:

- **Start Fully Open:** Begin with the valve dwell time set to its maximum (fully open - fully unscrewed). This allows the most air to enter the barrel, resulting in higher velocity but also higher air consumption.
- **Gradual Closure:** Slowly close the valve dwell time setting.
 - **Test for Consistency:** After each adjustment, fire several shots to check for shot consistency. You're looking for the setting where the velocity between shots is most uniform, not necessarily the highest.

Purpose of Adjustment:

Consistency Over Velocity: While you can fine-tune velocity with this setting, the primary goal is to achieve the best shot-to-shot consistency. This ensures your airgun performs accurately, whether you're plinking or competing.

Remember, finding the optimal dwell time might require some experimentation. It's about balancing velocity with efficiency and consistency, not just about maximizing one aspect.

Headspace Adjustment

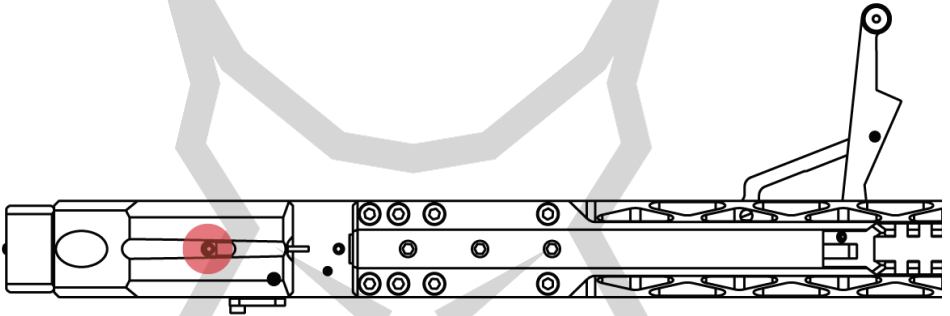

What is Headspace?: In airguns, headspace refers to the gap between the rifling and end of the projectile when it's seated in the barrel. Proper headspace ensures best accuracy. Typically you want to be past the transfer port with the projectile.

Accessing the Adjustment:

- **Cocking Handle:** Pull the cocking handle slightly back to access the grub screw on a pusher guide inside the rear block.
- **Grub Screw:** Locate and remove the grub screw pusher guide using 2.5 mm hex tool.

Adjusting the Pellet Pusher:

- **Rotation:** With the grub screw out, you can freely rotate the pellet pusher.
- **For Deeper Seating (Smaller Headspace):** Unscrew the pusher to make it longer, allowing the projectile to sit deeper in the barrel.
- **For Shallower Seating (Bigger Headspace):** Screw the pusher in to shorten it, which is typically better for slugs. Start with the pusher fully screwed in for slugs, and fully unscrewed for pellets (until it's flush with the pusher guide).

Securing the Adjustment:

- **Reinsert Grub Screw:** Once you've set your desired headspace, screw the grub screw back in fully.
- **Final Adjustment:** Back off the grub screw by 1/8 of a turn to allow the pusher to freely adjust to the chamber.

This adjustment ensures your projectiles are seated correctly for optimal performance. Remember, each adjustment might require some trial and error to find the sweet spot for your specific ammo.

Trigger Adjustment

Your Mora airgun allows for comprehensive trigger adjustments from the outside, ensuring you can tailor the trigger feel to your preference:

Sear Engagement Adjustment:

- **Location:** Found on the right side of the rear block, near the safety lever. Look for the sear icon. Use a 1.5 mm hex tool.
- **Adjustment:** Turn clockwise for less sear engagement (resulting in a lighter trigger pull), or counterclockwise for more engagement, making the trigger pull feel heavier but potentially safer.

Second Stage Pull Weight:

- **Location:** Adjacent to the sear engagement setting on the right side. Look for the spring icon. Use a 1.5 mm hex tool.

- **Adjustment:** Turn clockwise to increase the pull weight for a harder trigger, or counterclockwise to lighten it.

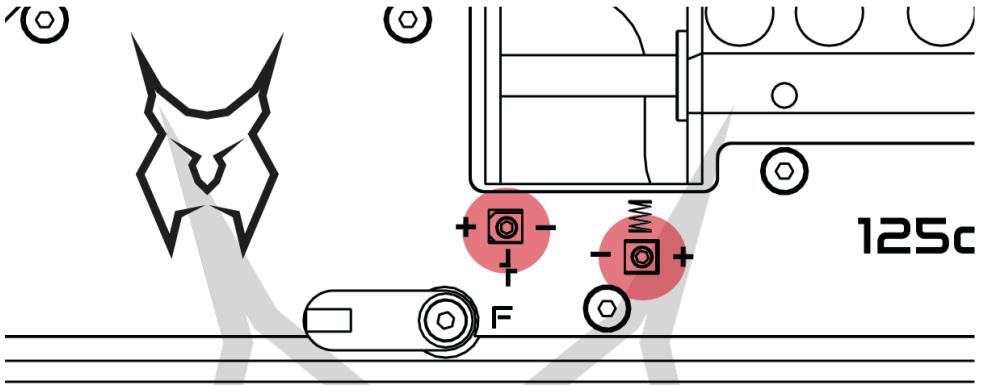

First Stage Weight Adjustment:

- **Remove Side Plate:** Take off the right side plate of the gun using a 2 mm hex tool.
- **C-Clip Positioning:** Adjust the C-clip's position; moving it further to the right increases the weight of the first stage pull.

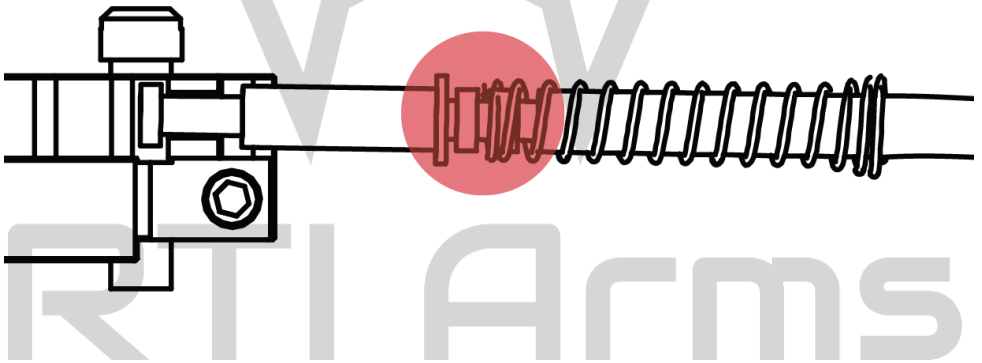

First Stage Travel:

- **Location:** Use a 2 mm tool at the front of the gun.
- **Adjustment:** Screwing in will shorten the travel of the first stage.

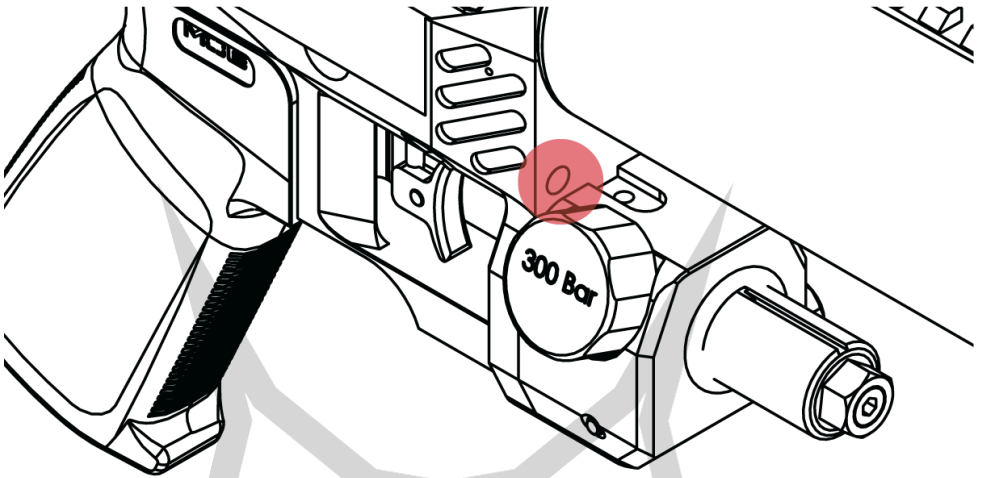

Trigger Blade Position:

- **Elevation and Rotation:** Loosen the 2 mm hex screw on the trigger blade itself to adjust its height or rotate it for better finger placement.
-

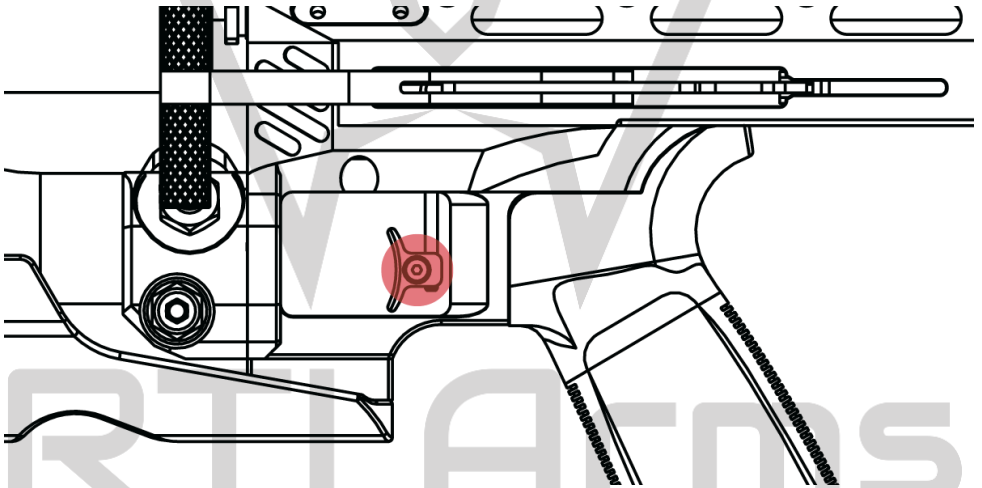

Safety Check After Adjustment:

After adjusting, ensure the trigger functions safely. Cock the gun (without projectiles) and simulate some rough movements to confirm the trigger doesn't fire unintentionally. Also, verify that the safety disengages correctly.

Important: Always ensure any adjustments do not compromise the safety of the airgun. Test thoroughly after each adjustment. The trigger should have a predictable break without being so light that it could lead to accidental discharge. Remember, a well-adjusted trigger enhances shooting precision, but safety should never be compromised for performance.

Buttpad Adjustment

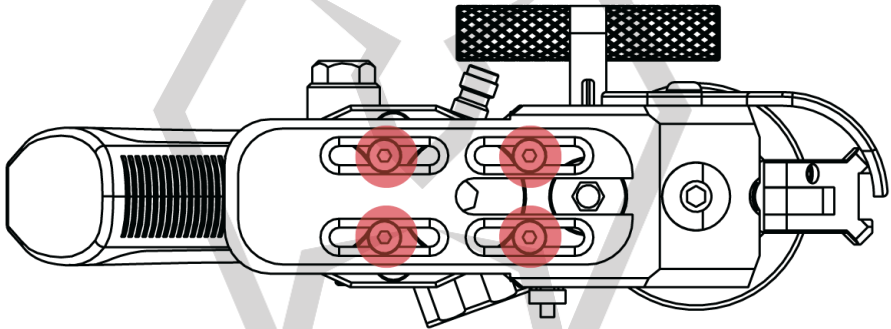

Adjusting the buttpad can help in customizing the feel and fit of the rifle against your shoulder, enhancing comfort and control.

Adjustment Process:

- **Remove Rubber Pad:** First, take off the rubber buttpad to access the adjustment mechanism.
- **Loosen Screws:** There are four screws holding the buttpad plate in place. Loosen these screws using a 2.5mm hex tool but do not remove them completely.

- **Adjust Position:** While the screws are loose, you can move the buttplate slightly up or down for a better fit.
- **Tighten Screws:** Once you've positioned the buttplate to your liking, tighten the screws to secure it in place.

This adjustment is more about fine-tuning the slight positioning of the buttplate. It ensures the rifle feels comfortable and well-balanced when you're shooting.

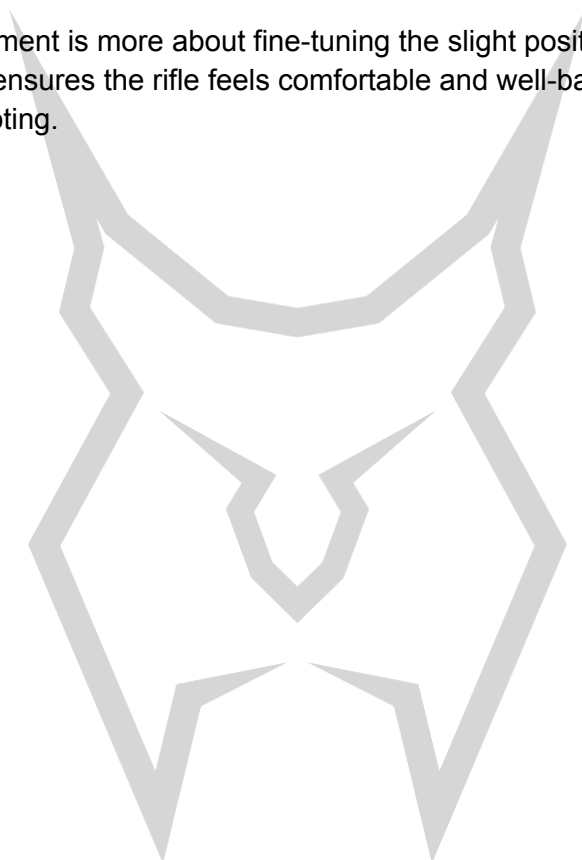

RTI Arms

Barrel change

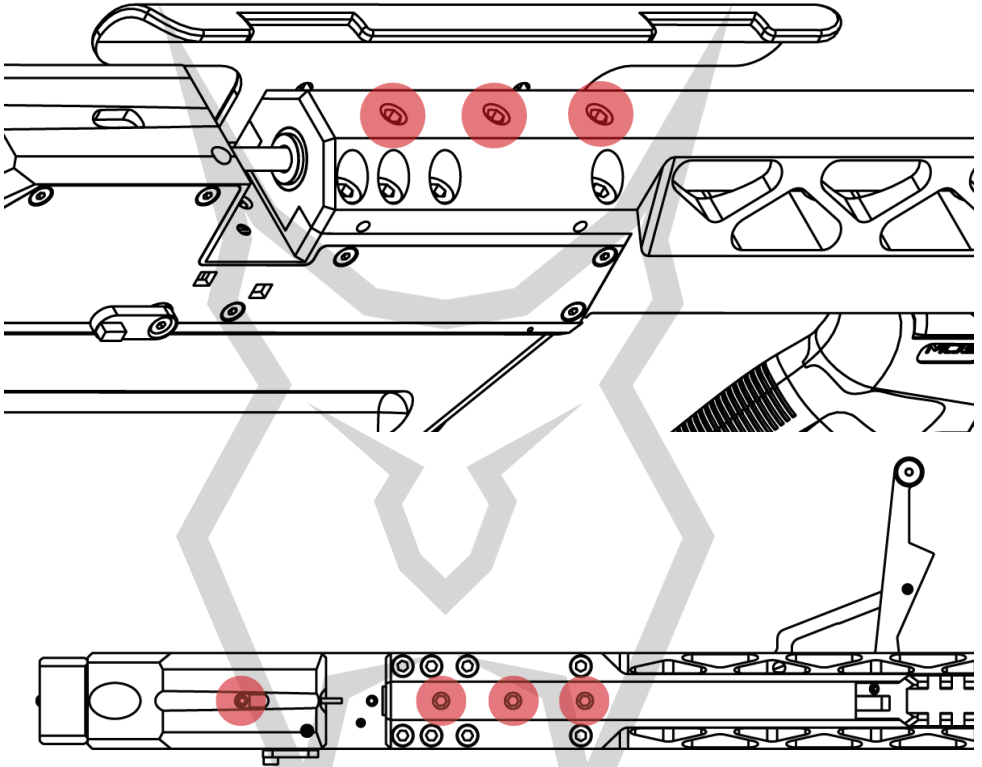

Preparation:

- **Cocking Handle:** Move the cocking handle halfway to clear the pellet probe from the barrel.

Removing the Barrel:

- **Front Nut:** If your barrel has a front nut, untighten it first. Skip this if there's no nut.

- **Breech Screws:** Remove one of the three screws securing the barrel to the breech using a 4 mm hex tool. Loosen the other two halfway.
- **Extract Barrel:** Pull the barrel out.

Removing Pellet Probe:

- **Fixing Screw:** Remove the screw holding the pellet probe.
- **Unscrew Probe:** Completely unscrew and remove the pellet probe.

Installing New Barrel:

- **Barrel Nut:** If using, slide the nut onto the new barrel before insertion.
- **Insert Barrel:** Push the new barrel into the gun.
- **Align Barrel:** Rotate until you see the flat surface through the screw hole in the breech block. The barrel's outer surface should be flush with the breech block.
- **Magazine Check:** Insert the magazine to ensure it clicks into place, indicating correct alignment.
- **Tighten Screws:** Gently tighten one of the two screws. Rotate the barrel slightly back and forth while tightening to ensure perfect alignment. Once aligned, tighten all three screws to 1,5 Nm.
- **Front Nut:** If your barrel has a front nut, tighten it to fix the barrel in place. Skip this if there's no nut.

Pellet Probe Installation:

- **Insert New Probe:** Fit the new pellet probe and secure it with the fixing screw.

Optional Shroud Transfer:

- **Transfer Process:** If your new barrel does not include a shroud, you have the option to transfer the shroud from your existing barrel to the new one.
- **Shroud Clamp Installation:**
 - **Positioning:** When installing a rear shroud clamp, ensure it's placed at the correct position on the barrel to properly secure the shroud.
 - **Tightening:** After positioning, tighten the clamp to 2,5 Nm. This ensures the shroud is securely attached.

This process allows you to switch calibers or barrels on your Mora airgun, ensuring optimal performance with different types of projectiles. Remember, precision in alignment is key for accuracy.

Maintenance

Witness holes

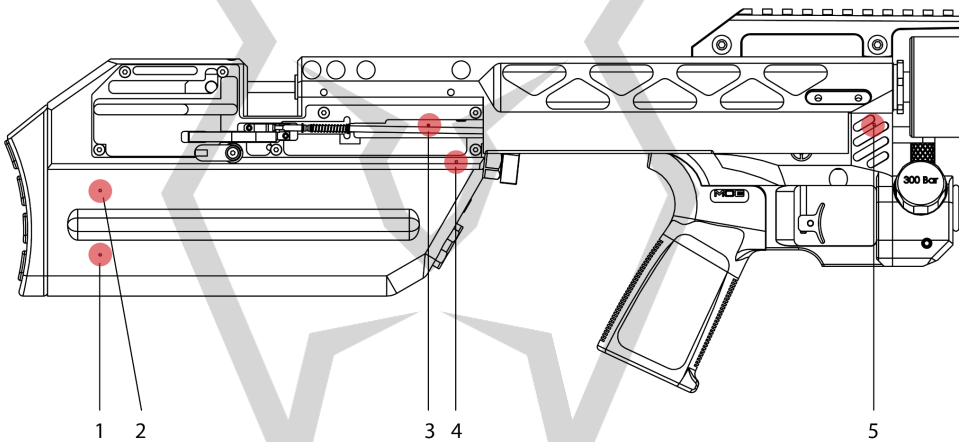

1. ID19x2.5 NBR70 - Plenum plug
2. ID19x2.5 NBR70 - Plenum plug
3. ID5x1.5 NBR70 - Connecting pipe
4. ID12x1.5 NBR70 or ID6x2 NBR70 - Valve spacer or Valve stopper
5. ID5x1.5 NBR70 - Connecting pipe

Your Mora Airgun features strategically placed witness holes all around. Here's how to use them for maintenance:

Purpose: Each hole corresponds to an O-ring inside the gun, allowing you to pinpoint leaks without disassembling the entire rifle.

Leak Detection Process:

- **Soapy Water:** Prepare a solution of soapy water.
- **Application:** Apply this solution around each witness hole.
- **Observation:** If you see bubbles forming at any hole, it indicates a leak at the corresponding O-ring.

Fixing the Leak:

- **Identify the O-ring:** Use the witness hole's location to determine which O-ring is compromised.
- **Disassemble:** Carefully take apart the section of the gun where the faulty O-ring is located. Make sure to do this in a clean environment to avoid introducing dirt into the system.
- **Prepare the Surface:** Before installing the new O-ring, make sure you clean the surface where the O-ring will be sealing. Remove any old lubricant, debris, or previous O-ring fragments to ensure a good seal.
- **Replace:** Replace the O-ring with a new one, ensuring it's properly lubricated with silicone oil.
- **Reassemble:** Put everything back together, ensuring all parts are correctly aligned and that the new O-ring is seated properly without being pinched or twisted.
- **Prevention:** Regularly check these witness holes with soapy water as part of your maintenance routine to catch potential leaks early.

This feature simplifies maintenance, making it easier to keep your Mora Airgun in top condition. Remember, a well-maintained airgun is a reliable airgun.

Miscellaneous Information

Warranty:

- **Duration:** Your RTI airgun comes with a 3-year warranty.
- **Contact:** Should you encounter any issues, contact the dealer from whom you purchased the gun first. They can guide you on the next steps or repairs under warranty.

Maintenance:

- **Cleanliness:** Regularly clean your airgun to ensure optimal performance and longevity.
- **Lubrication:** Use oil on steel parts to prevent rust.
- **Barrel Care:** Clean the barrel, but avoid using harsh chemicals or water, which can damage internal components.
- **Seals and O-Rings:** Use silicone oil on O-rings to keep them flexible and prevent them from drying out or cracking.

Storage:

- **Environment:** Store your rifle in a dry, dark place to prevent damage from humidity and sunlight.
- **Pressure:** Keep the rifle pressurized at around the regulated pressure to maintain seal integrity.
- **Corrosion Warning:** High humidity can lead to corrosion if not stored properly.
- **UV Damage:** Sunlight can degrade O-rings and affect anodized finishes.
- **Safety:** Never store the rifle loaded. Keep it out of reach of unauthorized individuals.

Safety Protocols: Always adhere to all safety warnings and guidelines provided. Remember, an airgun, while not a firearm, still requires responsible handling.

By following these guidelines, including the use of silicone oil on O-rings, you'll ensure your Mora airgun remains in top condition, ready for use

whenever you are. Proper care not only extends the life of your equipment but also enhances your shooting experience.



RTI Arms

Exploded Views

[Mora Exploded View](#)



[Regulator Exploded View](#)

